

Stainless Steel Continuous Hinges



General Information

CONTINUOUS BENEFITS

Security

Because Hager Companies' 790 Series Stainless Steel Continuous Hinges eliminate the gap between the door and frame, doors cannot be pried open.

Energy Savings

Stainless Steel Continuous hinges provide a permanent weather barrier and reduce air infiltration by creating a seal from top to bottom of the door at the hinge stile.

Heavy Duty, High-Quality Construction

14 Gauge Type 304 Stainless Steel Lubricated Nylon 6/6 bearings between each knuckle—stainless steel pin—corrosion resistant for swimming pool buildings, sewage and water treatment plants and salt spray environments. Ideal for hospitals and other institutions where doors and frames are subjected to severe abuse.

Improved Hardware Performance

Because doors stay properly aligned, Hager Companies' Continuous Hinges eliminate stress on closers, automatic operators, panic and locking hardware.

Support Doors Up to 600 lbs.

All models are designed for long life and heavy duty performance.

Ideal for Retrofit

Using existing frames, Hager Companies' 790 Series Stainless Steel Continuous Hinges cover the old butt hinge cut out locations.

Ease of Installation

Symmetrical, non-handed hole patterns on standard sizes.

Fire Rated

Hager Companies' 790 Series Stainless Steel Continuous Hinges are available with an Underwriters Laboratories Inc. fire label. Refer to the individual catalog pages for UL listing information.



Certification

Hager Companies' 790 Series Stainless Steel Continuous Hinges are approved for ANSI A156.26 Grade 1 for 150 lb. doors.

Privacy

Hager Companies' 790 Series Stainless Steel Continuous Hinges eliminate the gap or sightline at the hinge edge offering privacy on hospital or toilet partition applications.

Door Edge Guards

Various models are supplied with a 14 Gauge Stainless Steel Channel that wraps the door edge and protects the door edges from damage by carts, beds and equipment. Other models offer protection to the jamb with a wrap-around guard. Refer to individual catalog pages for additional information. Edge guards for the latch side edge of the door are available through our Trim and Auxiliary product line.

Standard Finish

Hager Companies' 790 Series Stainless Steel Continuous Hinges are brushed to a satin finish (US32D).

Recommended Lengths

Hager Companies' 790 Series Stainless Steel Continuous Hinges are always installed flush with the top edge of the door. Recommended head clearance is 1/8" (3.2 mm). Order each hinge equal to the net door height. In the field, trimming should be done from the bottom of the hinge only.

Added Features

Moldings are supplied to cover exposed fastener heads on half-surface and full-surface models and are screwed in place. Models with hinge guards are supplied with adjustable screws allowing up to 1/4" (9.5 mm) width adjustment for doors to be squared accurately and easily in new installations and retrofits.

DOOR AND FRAME PREPARATION

All 790 Series Stainless Steel Continuous Hinges are surface applied without cutouts. Cutout design and spacing coordination is thereby eliminated in both new construction and restoration work.

For models other than double edge guard models, reinforcement plates are not required in doors and frames except where the gauge is too thin or the material is too weak for the fasteners in relation to the door weight, or where abusive operation is anticipated. Consult the factory if there are questions.

For double edge guard models to be mounted to a hollow metal door, Hager Companies strongly recommends a 1/8" (3.2 mm) thick reinforcement plate at the hinge side of the door for proper strength of the adjustable studs. The added material will allow proper thread engagement and extend the life of the opening.

Blank frames may be ordered with strike prep only or with a strike prep furnished on both sides with any model that will cover the frame rabbet. Doors should always be ordered without cutouts except for use in labeled openings in which the tested door assembly may have manufacturing restrictions. Continuous frame mortar guards are strongly recommended for masonry walls to avoid screw fastener interference with the mortar.

DOOR CLOSERS

Conventional surface, concealed sliding closers and pivot-type floor closers may be used because doors stay properly aligned. Hager Companies Stainless Steel Continuous Hinges eliminate stress on closers, automatic operators, panic and locking hardware.

SPECIAL PRODUCTS

Custom Designs

Special designs for special applications. Contact Hager Companies Customer Service for more information.

While such orders become subject to the change and cancellation policy, hole positioning will be optimized to ensure that the appearance and operation of the products are maintained.



Stainless Steel Continuous Hinges

General Information

SPECIAL PRODUCTS (continued)

Custom Hole Pattern

Any hole pattern or shape other than Hager Companies' standard hole pattern. Contact Hager Companies Customer Service for more information. Available on all models.

Custom Length Hinges

Hager Companies manufactures hinges over 119" as two separate lengths. Hager Companies will select hinge segment lengths from standard sizes for best economics in relation to length required.

A special length should be specified from the net door height. To order, list the required hinge length dimension along with the "actual length" or "net door height."

Dutch Door Hinges

The frame leaf is furnished as a continuous leaf and the door leaf is cut to fit the dutch door heights specified. Upper and lower door leaves are prepped for extra screws. Handing, overall net door height, amount of clearance between the top and bottom doors, their individual heights and door and frame materials should be clearly specified.

Hospital Tips

Concealed models 790-900, 790-905, 790-907 and 790-915 can be prepared with a tapered 45° angle at the top of the hinge. These are ideal for use in hospitals and correctional facilities to help provide a clean and safe environment.

No-Hole (Blank) Hinges

Holes omitted for special applications (i.e. welded hinge) is available on all models. Contact Hager Companies Customer Service for more information.

Non-Rising Pin

The pin is held securely in place and will not rise or fall from the knuckles during use. The top and bottom plugs are permanently secured to the hinge.

Raised Barrel

For applications where the door is set back in the frame, the knuckle is offset to allow the hinge to clear the frame.

Replacement Moldings

Brushed aluminum replacement moldings with molding clips and fasteners are available in stock lengths for trimming in the field. 790-903, 190-904, 790-906, 790-909, 790-935.

Sheared Leaf

For narrow door thicknesses, leaf width can be trimmed. 790-900, 790-903, 790-905, 790-909, 790-911, 790-915, 790-926, 790-935.

Special Finishes

Hager Companies' 790 Series Stainless Steel Continuous Hinges are available in custom color painted or powder coated finishes. Color samples are required for matching.

Wide Throw

The width of the hinge leaf can be extended in order to clear the trim or wall conditions.

FASTENERS

Hager Companies' 790 Series Stainless Steel Continuous Hinges are provided exclusively with carefully engineered and thoroughly tested fasteners. Each fastener is designed for ease of use as well as durability. Appropriate fasteners are furnished with each hinge, together with installation instructions for typical metal and wood doors hung on metal frames. The standard screw pack includes Dril-Kwik® self-drilling screws for metal doors and frames as well as wood screws for wood doors.

Special adjustment studs and screws are standard on all models with the double door edge protection lip. The special adjustment studs and screws allow correction of door fit problems up to 3/8" (9 mm). Sex bolts are optional and must be requested at time of order. If special fasteners are required, customers must supply them except upon prior agreement. Please consult Hager Companies Technical Service for alternate fastener recommendations.

Security Fasteners

These fasteners improve building security and reduce hinge tampering. Security Torx are available in place of standard fasteners upon request.

Optional Sex Bolts

On all applicable full-surface and half-surface mounted hinge models, sex bolts can be ordered. Sex bolts are intentionally designed shorter than the door thickness to ensure proper clamping action of 1 3/4" (44 mm) doors of slightly varying thickness.

FASTENER INSTALLATION

Supplied standard with each hinge are two types of screws; the Dril-Kwik® self-drilling screw (with hardened drill point tip) and the thread forming wood screw. The Dril-Kwik® self-drilling screw is used in metal door and frame applications and has an undercut head and a machine thread on the screw shank. This wood screw is used on wood applications and has a type AB thread.

The Dril-Kwik® self-drilling screw's drill point allows it to be placed without pre-drilled holes when installed in a hollow metal frame less than 1/8" (3.2 mm) thick. It forms its own threads as it is drilled into the frame.

Mortar Guards, made of either styrofoam or wood, are recommended for new construction, eliminating the use of masonry bits. For existing grout-filled frames, pre-drilling is required before installation of the Dril-Kwik® self-drilling screws. Here, the screw acts as a machine screw since drilling has already taken place. Center-punching is recommended on both hollow metal and grout-filled frames to ensure that the screw seats properly in the hinge leaf. Stainless steel frames require pre-drilling.

In all cases, care should be taken to ensure that no drill chips build up behind the hinge. It is best to pre-mark the holes and pre-drill with the hinge removed or clamp the hinge very tightly against the door or frame when using the self-drilling screws.

When installing the self-drilling type screw, make certain that the installer is familiar with the proper use and torque settings of a screw gun. Proper center-punching is extremely important with self-drilling screws. If center-punching is omitted or incorrectly done, the screw will "walk" in the same way as a drill bit, resulting in cocked screw heads and improperly closing hinges.

Stainless Steel Continuous Hinges



General Information

DOOR AND FRAME DIMENSIONING

Models 790-900, 790-911, 790-915

Designed primarily for work involving new doors and frames

Clearance required as follows:

Single Doors (Square and Beveled Edged)

A. Hinge thickness	$7/32"$	5.6 mm
B. Additional allowance for frame irregularities	$1/32"$	0.8 mm
C. Lockside clearance for single door	$1/8"$	3.2 mm
Total	$3/8"$	9.5 mm

Pairs of Doors (Square and Beveled Edged)

A. Hinge thickness	$7/32"$	5.6 mm
B. Additional allowance for frame irregularities	$1/32"$	0.8 mm
C. Clearance between doors (typical)	$3/16"$	4.8 mm
D. Second hinge thickness	$7/32"$	5.6 mm
E. Second allowance for frame irregularities	$1/32"$	0.8 mm
Total	$11/16"$	17.5 mm

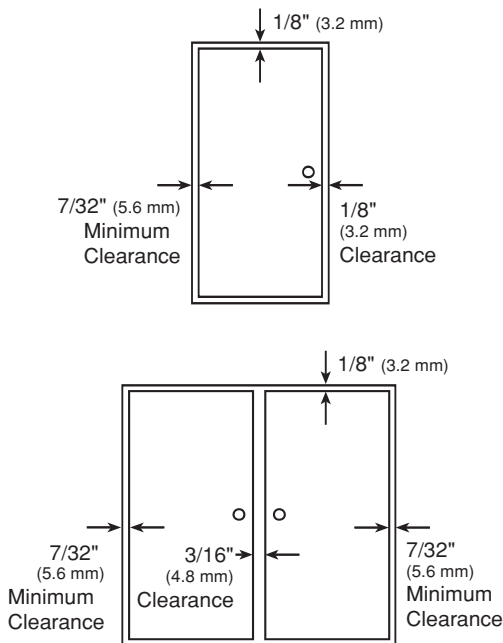

DOOR AND FRAME DIMENSIONING

Models 790-905, 790-926

Designed primarily for work involving new doors and frames

Clearance required as follows:

Single Doors (Square and Beveled Edged)

A. Hinge thickness	$9/32"$	7.1 mm
B. Additional allowance for frame irregularities	$1/32"$	0.8 mm
C. Lockside clearance for single door	$1/8"$	3.2 mm
Total	$7/16"$	11.1 mm

Pairs of Doors (Square and Beveled Edged)

A. Hinge thickness	$9/32"$	7.1 mm
B. Additional allowance for frame irregularities	$1/32"$	0.8 mm
C. Clearance between doors (typical)	$3/16"$	4.8 mm
D. Second hinge thickness	$9/32"$	7.1 mm
E. Second allowance for frame irregularities	$1/32"$	0.8 mm
Total	$13/16"$	20.6 mm

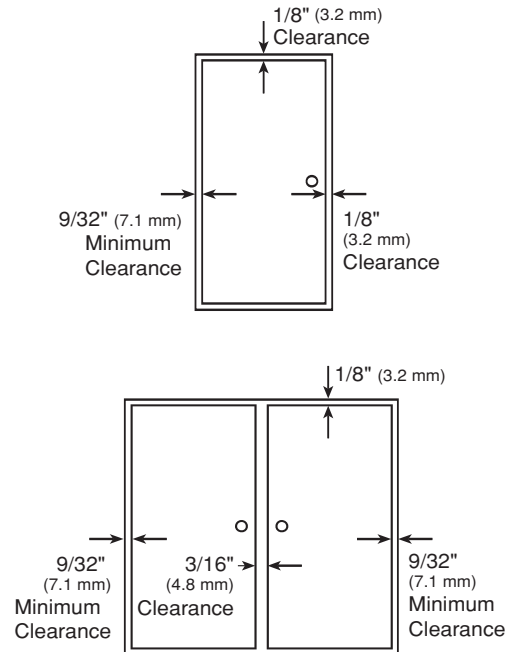

- Notes:
- Some minimal clearance may be required for paint and/or weatherstripping.
 - For doors that are pre-beveled $1/8"$ (3.2 mm)-in-2" (51 mm) on the hinge edge, add $1/32"$ (0.8 mm) per door to the TOTAL clearance shown (Model 790-900 only). For Models 790-911 and 790-915, the hinge edge of the door should not be beveled.

Note: Some minimal clearance may be required for paint and/or weatherstripping.



Stainless Steel Continuous Hinges

General Information

DOOR AND FRAME DIMENSIONING

Models 790-907

Designed primarily for work involving new doors and frames

Clearance required as follows:

Single Doors (Square Edged)

A. Hinge thickness	$\frac{3}{8}$ "	9.5 mm
B. Additional allowance for frame irregularities	$\frac{1}{32}$ "	0.8 mm
C. Lockside clearance for single door	$\frac{1}{8}$ "	3.2 mm
Total	$\frac{17}{32}$ "	13.5 mm

Pairs of Doors (Square Edged)

A. Hinge thickness	$\frac{3}{8}$ "	9.5 mm
B. Additional allowance for frame irregularities	$\frac{1}{32}$ "	0.8 mm
C. Clearance between doors (typical)	$\frac{3}{16}$ "	4.8 mm
D. Second hinge thickness	$\frac{3}{8}$ "	9.5 mm
E. Second allowance for frame irregularities	$\frac{1}{32}$ "	0.8 mm
Total	1"	25.4 mm

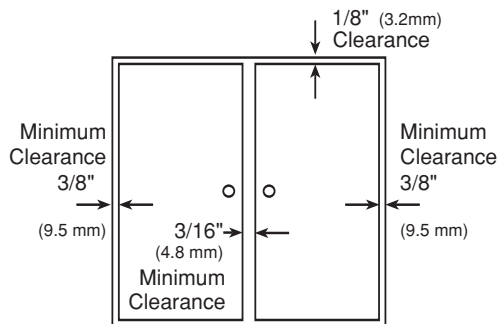
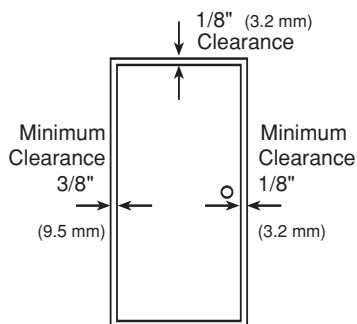

- Notes:
- Some minimal clearance may be required for paint and/or weatherstripping.
 - This model is not recommended for use on doors/panels that have a beveled edge on the hinge side.

DOOR AND FRAME DIMENSIONING

Models 790-903, 790-904, 790-906, 790-909, 790-935

Designed primarily for work involving new doors and frames

Clearance required as follows:

Single Doors (Square and Beveled Edged)

A. Hinge thickness	$\frac{1}{8}$ "	3.2 mm
B. Additional allowance for frame irregularities	$\frac{1}{32}$ "	0.8 mm
C. Lockside clearance for single door	$\frac{1}{8}$ "	3.2 mm
Total	$\frac{9}{32}$ "	7.2 mm

Pairs of Doors (Square and Beveled Edged)

A. Hinge thickness	$\frac{1}{8}$ "	3.2 mm
B. Additional allowance for frame irregularities	$\frac{1}{32}$ "	0.8 mm
C. Clearance between doors (typical)	$\frac{3}{16}$ "	4.8 mm
D. Second hinge thickness	$\frac{1}{8}$ "	3.2 mm
E. Second allowance for frame irregularities	$\frac{1}{32}$ "	0.8 mm
Total	$\frac{1}{2}$ "	12.7 mm

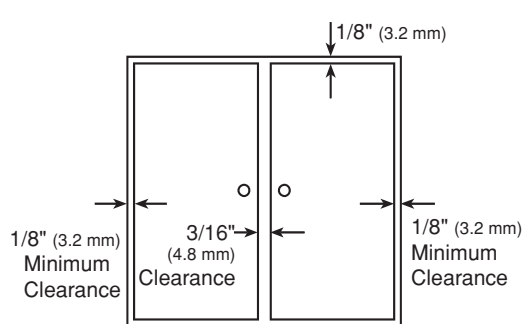
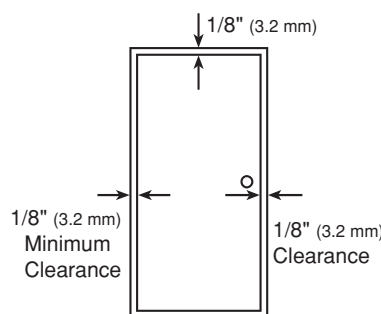

- Notes:
- Some minimal clearance may be required for paint and/or weatherstripping.
 - For doors that are pre-beveled $\frac{1}{8}$ " (3.2 mm)-in-2" (51 mm) on the hinge edge, add $\frac{1}{32}$ " (0.8 mm) per door to the TOTAL clearance shown (Model 790-904 only). For Model 790-906, the hinge edge of the door should not be beveled.

Stainless Steel Continuous Hinges



General Information

ELECTRIC MODIFICATIONS

Exposed Electric Switches:

- Miniature push button switch is incorporated in the hinge frame leaf to monitor position of the door
- Three 12" wire leads
- To order, use symbol "E1S" as a suffix
- Each monitoring hinge only needs one E1S switch
- Example: 790-900 85" US32D E1S
- Specify handing and dimension from top of hinge to centerline of electric through-wire location. Please note the clearance from top of hinge to underside of header, typically 1/16" to 1/8" (1.6 mm to 3.2 mm).
- Templates regarding location of contact switch available upon request

Concealed Electric Through-Wire:

- Transfers power discreetly from building to door hardware
- Four or eight 24 gauge 12" wire leads
- To order, use symbol "ETW" plus the number of wires required, as a suffix
- Example: 790-900 HD 85" US32D ETW - 4
- Specify handing and dimension from top of hinge to centerline of electric through-wire location. Please note the clearance from top of hinge to underside of header, typically 1/16" to 1/8" (1.6 mm to 3.2 mm).
- Available on the following models: 790-900 & 790-915

Von Duprin EPT2 or EPT10 Electric Power Transfer Preparation

- Hinge leaf cutout to accommodate power transfer device
- Specify handing and dimension from top of hinge to centerline of power transfer cutout location. Please note the clearance from top of hinge to underside of header, typically 1/16" to 1/8" (1.6 mm to 3.2 mm).
- Modification available on models: 790-900, 790-903, 790-904, 790-915

Mortar Box - 430

- Serves as a mortar shield
- Overall dimensions: 9" (229 mm) length with tabs, 7" (178 mm) (inside), 1 3/4" x 1 3/4" (45 mm x 45 mm) inside dimension
- Galvanized steel 0.040" (1 mm)
- Top and bottom knockouts for standard conduit fittings

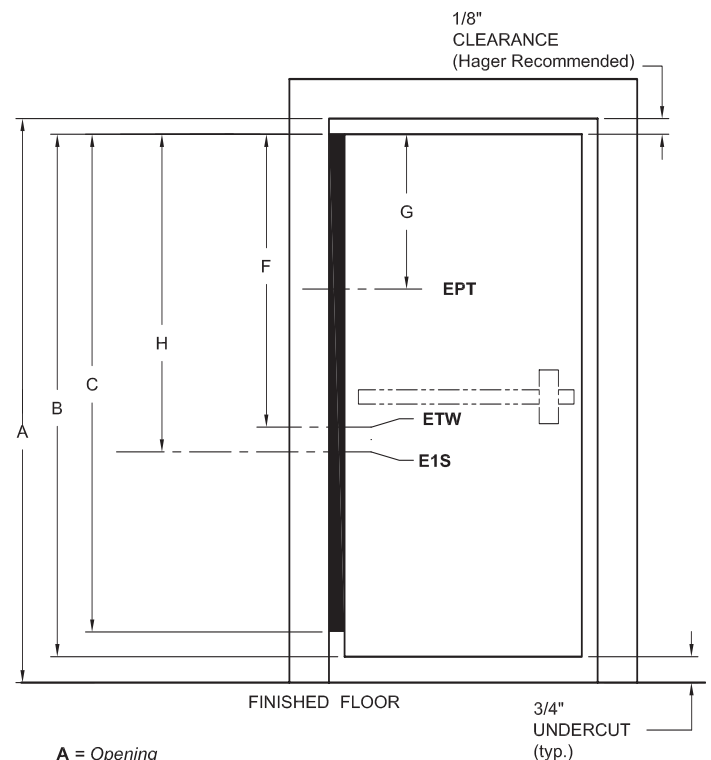

- A = Opening
- B = Door height
- C = Actual hinge length
- F = C.L. of ETW (electric through-wires)
- G = C.L. of EPT (electric power transfer)
- H = C.L. of E1S (exposed switch)

	79"	83"	85"	95"	119"
A	80"	84"	86"	96"	120"
B	79 1/8"	83 1/8"	85 1/8"	95 1/8"	119 1/8"
C	79 3/16"	83 1/8"	85 1/8"	95"	118 3/4"
F	41 1/2"	43 1/2"	45 1/2"	55 3/8"	79 1/8"
G	24 1/2"	28 7/16"	30 7/16"	40 1/2"	64 7/16"
H	41 1/2"	43 1/2"	45 1/2"	55 3/8"	79 1/8"

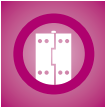

Stainless Steel Continuous Hinges

Concealed Leaf

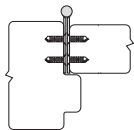

Door of Any Material

For 1 3/4" (44 mm) doors up to 600 lbs.

790-900



Material: 14 Ga. (0.075" = 1.9 mm) Type 304 Stainless Steel

Finish: US32D Satin

Clearance: 7/32" (5.6 mm) hinge side plus standard lockside clearance

Fasteners: #10-24 x 5/8" S/S Drill-Kwik® (metal frame/door)
#10-16 x 1 1/4" S/S Type AB (wood door)

Length Options: Standard and custom

Door Reinforcement: None required to 200 lbs.

Frame Reinforcement: None required to 200 lbs. Heavier weight use 16 gauge channel

Fire Rating: Up to 3 hour metal and 90 minute wood composite

- Special Features:
- 1/4" (6.3 mm) diameter Stainless Steel Pin
 - Dual 6/6 Nylon bearings between each knuckle
 - May be used with beveled or square edge doors
 - 1/8" (3.2 mm) inset

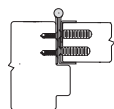

Door of Any Material

For 1 3/4" (44 mm) doors up to 600 lbs.

790-905



Material: 14 Ga. (0.075" = 1.9 mm) Type 304 Stainless Steel

Finish: US32D Satin

Clearance: 9/32" (7.1 mm) minimum hinge side plus standard lockside clearance

Fasteners: #10-24 x 5/8" S/S Drill-Kwik® (metal frame)
#1/4-32 x 3/4" S/S machine screw (used with adjustment stud)
#3/8-16 x 1-3/8" S/S adjustment stud (metal/wood door)

Length Options: Standard and custom

Door Reinforcement: Wood – None required

Metal – Recommended 16 gauge channel at heavier weight

Frame Reinforcement: None required

Fire Rating: Up to 3 hour metal and 90 minute wood composite

- Special Features:
- 1/4" (6.3 mm) diameter Stainless Steel Pin
 - Dual 6/6 Nylon bearings between each knuckle
 - Door edge protection lip (both faces of door)
 - Not recommended for doors with a beveled edge on the hinge side
 - 1/16" (1.6 mm) inset

Hinge Length - Inches	79	83	85	95	119
Hinge Length - cm	200.7	210.8	215.9	241.3	302.3
Door Screws	19	21	21	23	27
Jamb Screws	19	21	21	23	27

Hinge Length - Inches	79	83	85	95	119
Hinge Length - cm	200.7	210.8	215.9	241.3	302.3
Door Screws	19	21	21	23	27
Jamb Screws	19	21	21	23	27

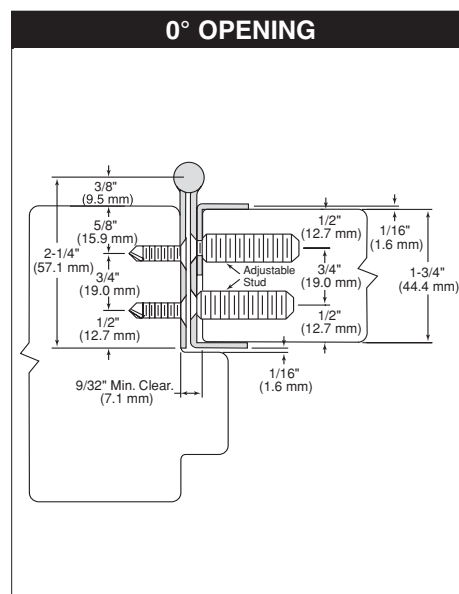
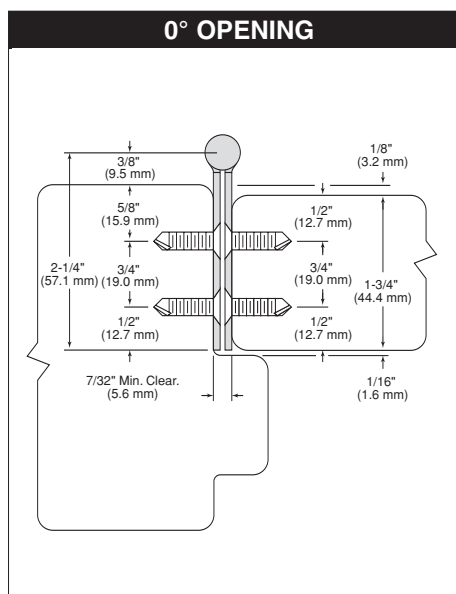

Stainless Steel Continuous Hinges



Concealed Leaf

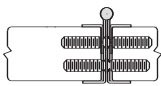

Flush Mount - Door of Any Material

For 1 3/4" (44 mm) doors up to 600 lbs.

790-907



Material: 14 Ga. (0.075" = 1.9 mm) Type 304 Stainless Steel
Finish: US32D Satin
Clearance: 3/8" (9.5 mm) minimum clearance between doors
Fasteners: #10-32 x 3/4" S/S machine (used with adjustment stud)
 #3/8-16 x 1 3/8" S/S adjustment stud (metal/wood door)

Length Options: Standard

Door Reinforcement: Wood – None required up to to 200 lbs.
 Metal – Recommended w/16 gauge channel at heavier weight

Frame Reinforcement: None required to 200 lbs. Heavier weight use 16 gauge channel

Fire Rating: Up to 3 hour metal and 90 minute wood composite

- Special Features:**
- 1/4" (6.3 mm) diameter Stainless Steel Pin
 - Dual 6/6 Nylon bearings between each knuckle
 - Door edge protection lip (both faces of door)
 - Can be used for door to door mounting
 - Not recommended for doors with a beveled edge on the hinge side

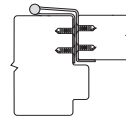

Swing Clear - Door of Any Material

For 1 3/4" (44 mm) doors up to 600 lbs.

790-911



Material: 14 Ga. (0.075" = 1.9 mm) Type 304 Stainless Steel
Finish: US32D Satin
Clearance: 7/32" (5.6 mm) hinge side plus standard lockside clearance
Fasteners: #10-24 x 5/8" S/S Drill-Kwik® (metal frame/door)
 #10-16 x 1 1/4" S/S Type AB (wood door)

Length Options: Standard and custom

Door Reinforcement: None required to 200 lbs. Heavier weight use 16 gauge channel

Frame Reinforcement: None required to 200 lbs. Heavier weight use 16 gauge channel

Fire Rating: Up to 3 hour metal and 90 minute wood composite

- Special Features:**
- 1/4" (6.3 mm) diameter Stainless Steel Pin
 - Dual 6/6 Nylon bearings between each knuckle
 - Wrap-around frame leaf design for easy installation and protection
 - Door edge protection lip (stop side only)
 - Useful for ADA upgrade work
 - Not recommended for doors with a beveled edge on the hinge side

Hinge Length - Inches	79	83	85	95	119
Hinge Length - cm	200.7	210.8	215.9	241.3	302.3
Door Screws	19	21	21	23	27
Jamb Screws	19	21	21	23	27

Hinge Length - Inches	79	83	85	95	119
Hinge Length - cm	200.7	210.8	215.9	241.3	302.3
Door Screws	19	21	21	23	27
Jamb Screws	19	21	21	23	27

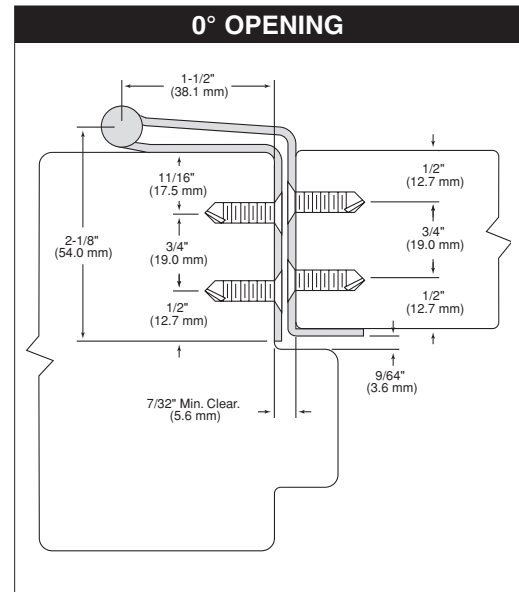
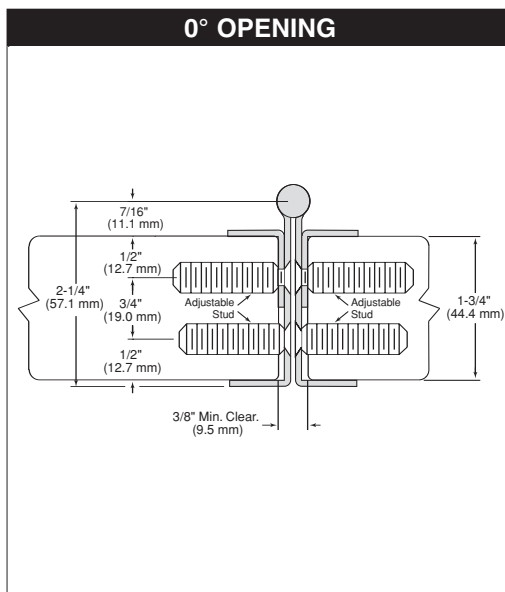



Stainless Steel Continuous Hinges

Concealed Leaf

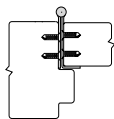

Door of Any Material

For 1 3/4" (44 mm) doors up to 600 lbs.

790-915



Material: 14 Ga. (0.075" = 1.9 mm) Type 304 Stainless Steel

Finish: US32D Satin

Clearance: 7/32" (5.6 mm) plus standard lockside clearance

Fasteners: #10-24 x 5/8" S/S Dril-Kwik® (metal frame/door)
#10-16 x 1 1/4" S/S Type AB (wood door)

Length Options: Standard and custom

Door Reinforcement: None required to 200 lbs. Heavier weight use 16 gauge channel

Frame Reinforcement: None required

Fire Rating: Up to 3 hour metal and 90 minute wood composite

Special Features:

- 1/4" (6.3 mm) diameter Stainless Steel Pin
- Dual 6/6 Nylon bearings between each knuckle
- Door edge protection lip (stop side only)
- Not recommended for doors with a beveled edge on the hinge side
- 1/16" (1.6 mm) inset

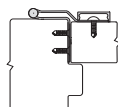

Swing Clear - Door of Any Material

For 1 3/4" (44 mm) doors up to 600 lbs.

790-926



Material: 14 Ga. (0.075" = 1.9 mm) Type 304 Stainless Steel

Finish: US32D Satin

Clearance: 9/32" (7.1 mm) minimum hinge side plus standard lockside clearance

Fasteners: #10-24 x 5/8" S/S Dril-Kwik® (metal frame)
#10-32 x 3/4" S/S machine (used with adjustment stud)
#3/8-16 x 1 3/8" S/S adjustment stud (metal/wood door)

Length Options: Standard and custom

Door Reinforcement: None required to 200 lbs. Heavier weight use 16 gauge channel

Frame Reinforcement: None required to 200 lbs. Heavier weight use 16 gauge channel

Fire Rating: Up to 3 hour metal and 90 minute wood composite

Special Features:

- 1/4" (6.3 mm) diameter Stainless Steel Pin
- Dual 6/6 Nylon bearings between each knuckle
- Wrap-around frame leaf design for easy installation and protection
- Door edge protection lip (both faces of door)
- Useful for ADA upgrade work
- Not recommended for doors with a beveled edge on hinge side

Hinge Length - Inches	79	83	85	95	119
Hinge Length - cm	200.7	210.8	215.9	241.3	302.3
Door Screws	19	21	21	23	27
Jamb Screws	19	21	21	23	27

Hinge Length - Inches	79	83	85	95	119
Hinge Length - cm	200.7	210.8	215.9	241.3	302.3
Door Screws	19	21	21	23	27
Jamb Screws	19	21	21	23	27

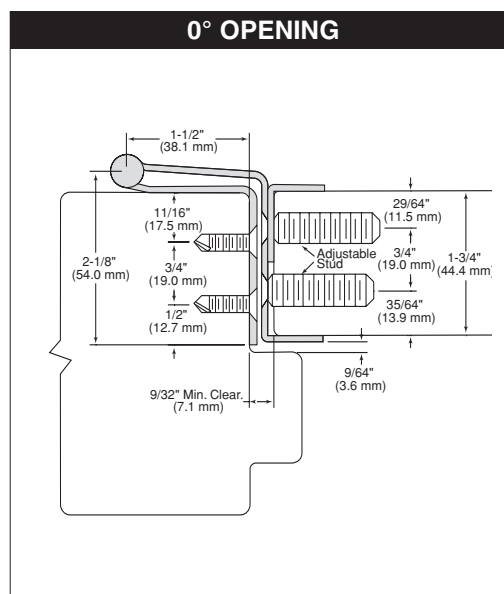
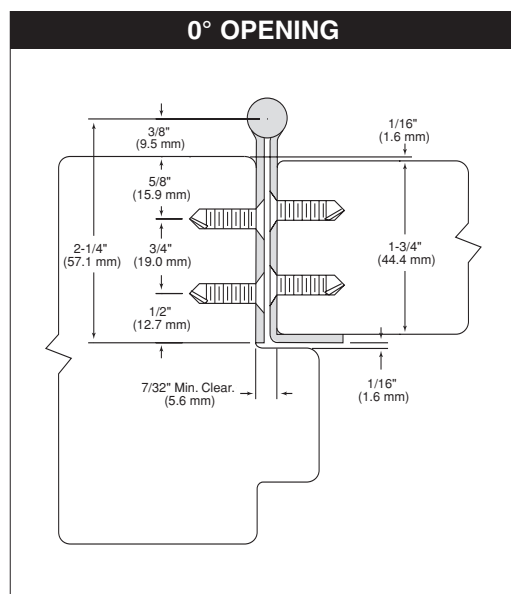

Stainless Steel Continuous Hinges

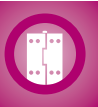

Half Surface

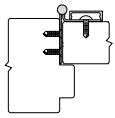

Door of Any Material

For 1 3/4" (44 mm) doors up to 600 lbs.

790-903



Material: 14 Ga. (0.075" = 1.9 mm) Type 304 Stainless Steel
 Finish: US32D Satin
 Clearance: 1/8" (3.2 mm) minimum hinge side plus standard lockside clearance
 Fasteners: #10-24 x 5/8" S/S Dril-Kwik® (metal frame)
 #1/4-20 x 3/4" 2C Dril-Kwik® (metal door)
 #1/4-14 x 1" 2C Type AB (wood door)

Length Options: Standard

Door Reinforcement: None required to 200 lbs. Heavier weight use 16 gauge channel

Frame Reinforcement: None required to 200 lbs. Heavier weight use 16 gauge channel

Fire Rating: Up to 3 hour metal and 90 minute wood composite

- Special Features:
- 1/4" (6.3 mm) diameter Stainless Steel Pin
 - Dual 6/6 Nylon bearings between each knuckle
 - Security molding
 - 1/8" (3.2 mm) inset

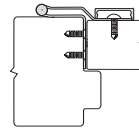

Swing Clear - Door of Any Material

For 1 3/4" (44 mm) doors up to 600 lbs.

790-935



Material: 14 Ga. (0.075" = 1.9 mm) Type 304 Stainless Steel
 Finish: US32D Satin
 Clearance: 1/8" (3.2 mm) minimum hinge side plus standard lockside clearance
 Fasteners: #10-24 x 5/8" S/S Dril-Kwik® (metal frame)
 #1/4-20 x 3/4" 2C Dril-Kwik® (metal door)
 #1/4-14 x 1" 2C Type AB (wood door)

Length Options: Standard

Door Reinforcement: None required to 200 lbs. Heavier weight use 16 gauge channel

Frame Reinforcement: None required

Fire Rating: Up to 3 hour metal and 90 minute wood composite

- Special Features:
- 1/4" (6.3 mm) diameter Stainless Steel Pin
 - Dual 6/6 Nylon bearings between each knuckle
 - Wrap-around frame leaf design for easy installation and protection
 - Useful for ADA upgrade work
 - Security molding
 - 1/8" (3.2 mm) inset

Hinge Length - Inches	79	83	85	95	119
Hinge Length - cm	200.7	210.8	215.9	241.3	302.3
Door Screws	13	14	14	15	18
Jamb Screws	19	21	21	23	27

Hinge Length - Inches	79	83	85	95	119
Hinge Length - cm	200.7	210.8	215.9	241.3	302.3
Door Screws	13	14	14	15	18
Jamb Screws	19	21	21	23	27

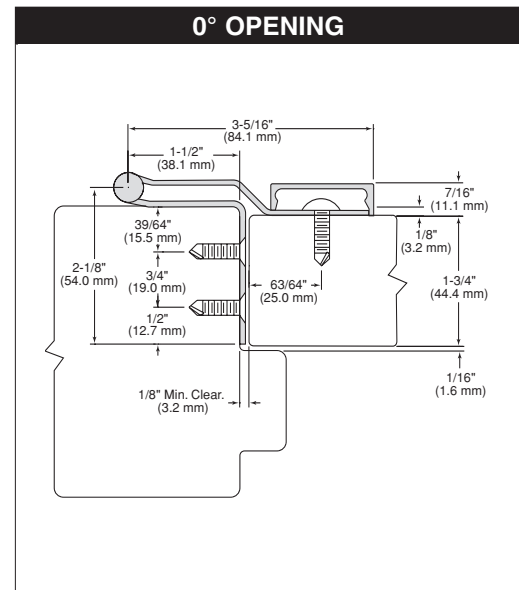
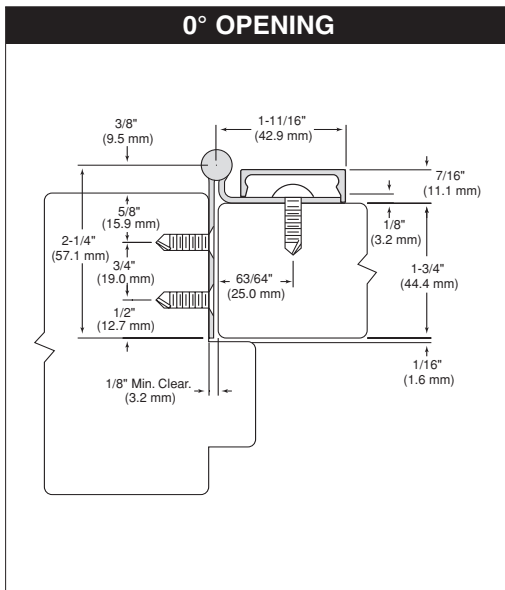



Stainless Steel Continuous Hinges

Half Mortise

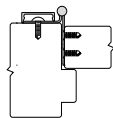

Door of Any Material

For 1 3/4" (44 mm) doors up to 600 lbs.

790-904



Material: 14 Ga. (0.075" = 1.9 mm) Type 304 Stainless Steel
Finish: US32D Satin
Clearance: 1/8" (3.2 mm) hinge side plus standard lockside clearance
Fasteners: #10-24 x 5/8" S/S Dril-Kwik® (metal door)
 #1/4-20 x 3/4" 2C Dril-Kwik® (metal frame)
 #10-16 x 1 1/4" S/S Type AB (wood door)

- Length Options:** Standard
Door Reinforcement: None required
Frame Reinforcement: None required to 200 lbs. Heavier weight use 16 gauge channel
Fire Rating: Up to 3 hour metal and 90 minute wood composite
Special Features:
- 1/4" (6.3 mm) diameter Stainless Steel Pin
 - Dual 6/6 Nylon bearings between each knuckle
 - Not recommended for doors with a beveled edge on the hinge side
 - 1/8" (3.2 mm) inset

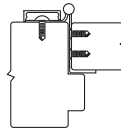

Door of Any Material

For 1 3/4" (44 mm) doors up to 600 lbs.

790-906



Material: 14 Ga. (0.075" = 1.9 mm) Type 304 Stainless Steel
Finish: US32D Satin
Clearance: 1/8" (3.2 mm) hinge side plus standard lockside clearance
Fasteners: #10-24 x 5/8" S/S Dril-Kwik® (metal door)
 #1/4-20 x 3/4" 2C Dril-Kwik® (metal jamb)
 #10-16 x 1 1/4" S/S Type AB (wood door)
 #1/4-14 x 1" 2C Type AB (wood frame)

- Length Options:** Standard
Door Reinforcement: None required
Frame Reinforcement: None required to 200 lbs. Heavier weight use 16 gauge channel
Fire Rating: Up to 3 hour metal and 90 minute wood composite
Special Features:
- Door edge protection lip stop side only
 - 1/4" (6.3 mm) diameter Stainless Steel Pin
 - Dual 6/6 Nylon bearings between each knuckle
 - For square edge doors only. Not recommended for doors with a beveled edge on the hinge side

Hinge Length - Inches	79	83	85	95	119
Hinge Length - cm	200.7	210.8	215.9	241.3	302.3
Door Screws	19	21	21	23	27
Jamb Screws	13	14	14	15	18

Hinge Length - Inches	79	83	85	95	119
Hinge Length - cm	200.7	210.8	215.9	241.3	302.3
Door Screws	19	21	21	23	27
Jamb Screws	13	14	14	15	18

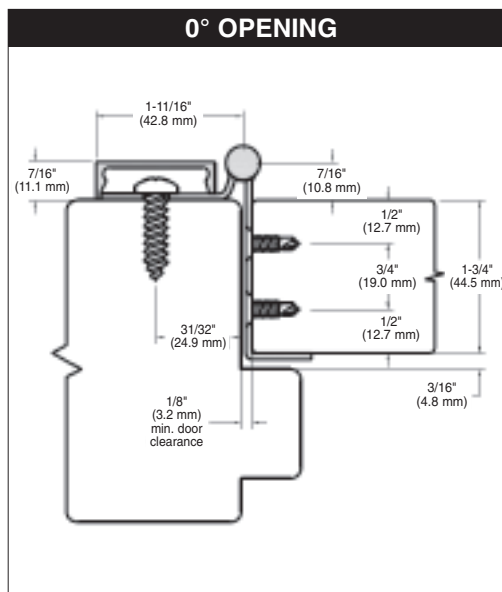
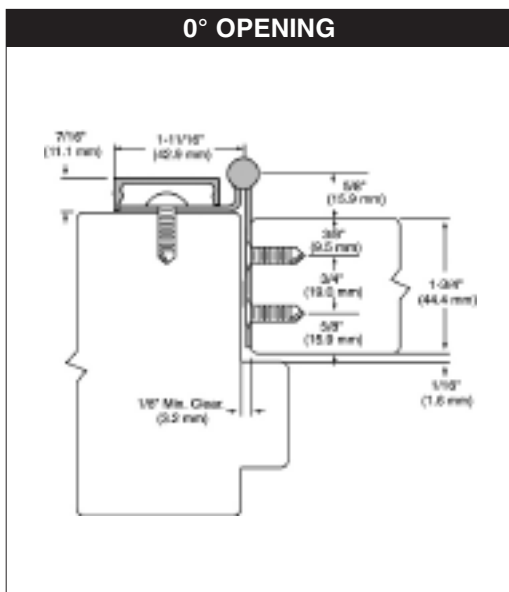

Stainless Steel Continuous Hinges



Full Surface

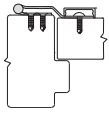

Swing Clear - Door of Any Material

For 1 3/4" (44 mm) doors up to 600 lbs.

790-909



Material: 14 Ga. (0.075" = 1.9 mm) Type 304 Stainless Steel

Finish: US32D Satin

Clearance: 1/32" (0.8 mm) minimum recommended hinge side plus standard lockside clearance

Fasteners: #10-24 x 5/8" S/S Dril-Kwik® (metal frame)
#1/4-20 x 3/4" 2C Dril-Kwik® (metal door)
#1/4-14 x 1" 2C Type AB (wood door)

Length Options: Standard

Door Reinforcement: None required to 200 lbs. Heavier weight use 16 gauge channel

Frame Reinforcement: None required to 200 lbs. Heavier weight use 16 gauge channel

Fire Rating: Up to 3 hour metal and 90 minute wood composite

Special Features: • 1/4" (6.3 mm) diameter Stainless Steel Pin

• Dual 6/6 Nylon bearings between each knuckle

• Useful for ADA upgrade work

• Security molding

• For beveled or square edge doors

• 1/8" (3.2 mm) inset

Hinge Length - Inches	79	83	85	95	119
Hinge Length - cm	200.7	210.8	215.9	241.3	302.3
Door Screws	13	14	14	15	18
Jamb Screws	19	21	21	23	27

